

7.1 Type: FSU (DIN69051)

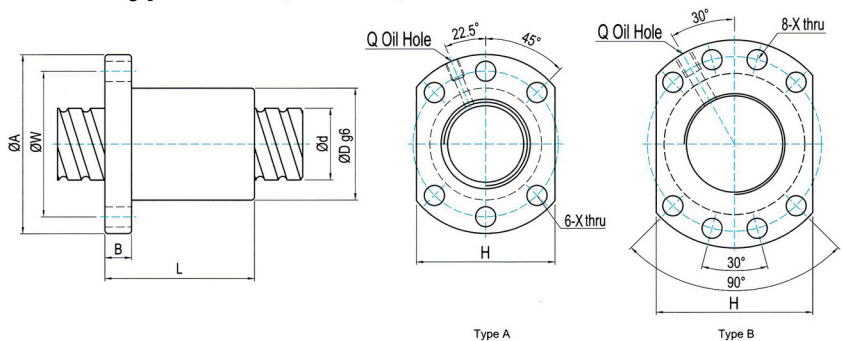

Type A

Type B

單位 : mm

型號	規 格														
	d	l	Da	D	A	B	L	W	X	Type	H	Q	n	Ca(Kgf)	Coa(kgf)
1604-4	16	4	2.381	28	48	10	45	38	5.5	A	40	M6	T4	944	1254
★ 1605-3	16	5	3.175	28	48	10	42	38	5.5	A	40	M6	T3	1049	1144
★ 1605-4	16	5	3.175	28	48	10	50	38	5.5	A	40	M6	T4	1344	1525
1610-3	16	10	3.175	28	48	12	65	38	5.5	A	40	M6	T3	1084	1232
2005-3	20	5	3.175	36	58	10	47	47	6.6	A	44	M6	T3	1181	1496
★ 2005-4	20	5	3.175	36	58	10	53	47	6.6	A	44	M6	T4	1512	1995
2006-3	20	6	3.969	36	58	10	52	47	6.6	A	44	M6	T3	1569	1788
2010-3	20	10	3.969	36	58	10	68	47	6.6	A	44	M6	T3	1621	1925
2504-4	25	4	2.381	40	62	11	46	51	6.6	A	48	M6	T4	1178	2046
2505-3	25	5	3.175	40	62	10	47	51	6.6	A	48	M6	T3	1330	1936
★ 2505-4	25	5	3.175	40	62	10	53	51	6.6	A	48	M6	T4	1704	2581
2510-3	25	10	4.762	40	62	12	75	51	6.6	A	48	M6	T3	2250	2772
2510-4	25	10	4.762	40	62	12	85	51	6.6	A	48	M6	T4	2881	3695
★ 3205-4	32	5	3.175	50	80	12	53	65	9	A	62	M6	T4	1924	3403
3206-4	32	6	3.969	50	80	12	58	65	9	A	62	M6	T4	2598	4217
3210-3	32	10	6.35	50	80	16	77.5	65	9	A	62	M6	T3	3775	5877
3210-4	32	10	6.35	50	80	16	90	65	9	A	62	M6	T4	4834	7835
★ 4005-4	40	5	3.175	63	93	16	56	78	9	B	70	M8	T4	2142	4342
4006-4	40	6	3.969	63	93	14	60	78	9	B	70	M6	T4	2877	5318
4010-4	40	10	6.35	63	93	18	93	78	9	B	70	M8	T4	5399	10074
5006-4	50	6	3.969	75	110	15	62	93	11	B	85	M8	T4	3203	6784
5010-4	50	10	6.35	75	110	18	93	93	11	B	85	M8	T4	5933	12313
6310-4	63	10	6.35	90	125	18	98	108	11	B	95	M8	T4	6700	16230
6320-3	63	20	9.525	95	135	20	138	115	13.5	B	100	M8	T3	8957	17945
8010-4	80	10	6.35	105	145	20	98	125	13.5	B	110	M8	T4	7547	21268
8020-3	80	20	9.525	125	165	25	143	145	13.5	B	130	M8	T3	10168	23611